



OPERATING INSTRUCTIONS FOR RESIDENTS

VertoBlue household display and VertoMobile

verto.fi





CONTENTS

General.....	3
Overall consumption view.....	4
Weekly view.....	5
TRIP view.....	6
Date, time and household temperature.....	7
Additional information and settings.....	8
Settings 1 VertoMobile.....	9
Settings 2 Language options.....	10

GENERAL

The Verto household display has icons for hot and cold water to help you identify your household's water consumption.



Hot



Cold



Change view





Function button

The household display can be placed conveniently in the apartment using the wall mount that is included in the delivery.

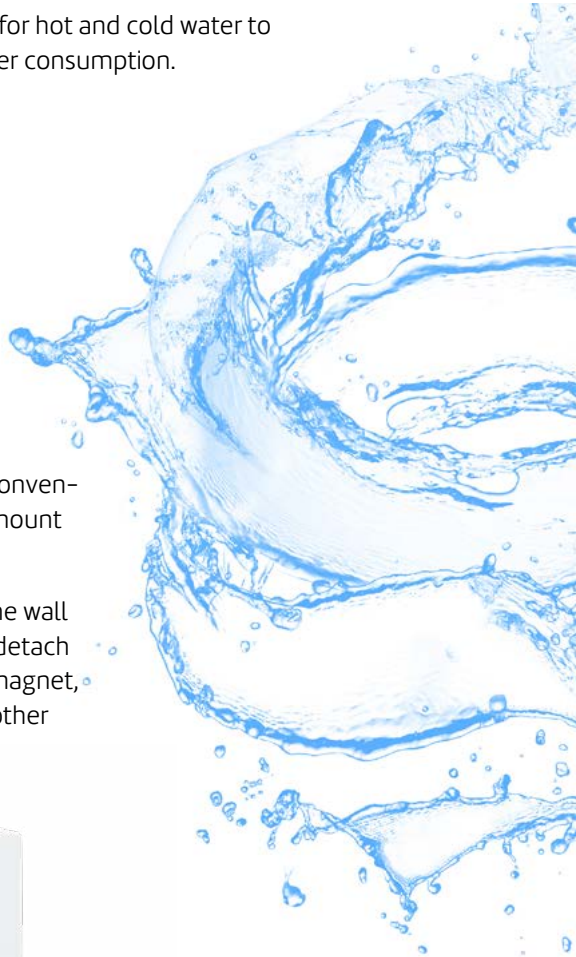
The household display is attached to the wall mount by a magnet, making it easy to detach and reattach it as necessary. With the magnet, the display can also be attached to another suitable location in the apartment.



Overall consumption view

The household display is turned on by touching the button  or  .
Number of views; How to proceed on the display.

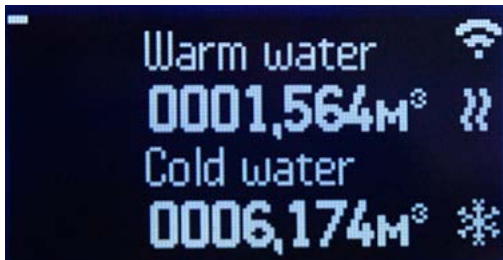

The overall view displays the total consumption of hot and cold water.

 displays device connection status.

Weekly view

- Household water consumption for the past seven days.
- The bar on the far right displays the consumption of the current day.
- Current day consumption is also displayed as a numerical value.

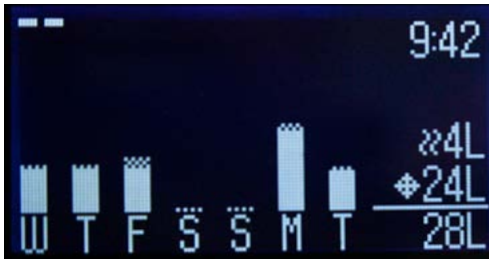

The bars in the view have two sections, white for cold water and grid for hot water. Under each bar there is a letter denoting the day of the week. The day starts at 0:00 local time.

The bars scale automatically based on the highest consumption on the weekly view.



TRIP view

With Trip views, you can monitor your water consumption for a given period.

- Trip is switched on and off by pressing the  button on the display.
- Trip measurements are similar.



Trip start:

1. Select (Trip 1 or Trip 2).
 2. Press and hold the  button for a few seconds until a text is displayed. Measurement starts automatically and the text will disappear.
 3. When measurement starts, the 'Start' text on the display will change to 'Stop'. The clock  starts.
- The clock displays the total time measured. The clock automatically scales to hours and days.
 - The timer  displays the total duration of how long water has been used during the measurement. The duration of water usage is initially displayed in minutes, later in hours and days.
 - The large numbers display the total water consumption for the measured period. The small numbers below display the consumption of hot and cold water separately.

Trip stop:

4. Press and hold the  button for a few seconds until a text is displayed. Measurement stops automatically and the text disappears. The data will be stored until the start of the next measurement.



Date, time and household temperature



After the batteries are replaced, it will take a moment until the temperature is updated.





Additional information view

From the view, go to settings by pressing the  button.

- Select litre or m³ as the measurement unit with the  button.
Confirm the selection by pressing the  button.



The view features the following additional information:

1. Status of display batteries. The display operates on two AA batteries.
To change the batteries, open the back cover of the display.
2. When the household display is connected to the household unit, it is shown by the  symbol.
3. Status of connection between display and water meters.
 - a. The view has 1-2  symbols depending on the number of water meters in the household.
 - b. The signal strength is  . No connection  .
4. To go to settings, press the .

Settings 1: VertoMobile

Displays the household's PIN code, which is used to log into the VertoMobile app.



VertoMobile is an app that works with the household display. Residents can use it on their smartphones to monitor the household's water consumption. You can download VertoMobile and monitor water consumption data on as many smartphones as you like.

The app is available for Android devices on the Google Play store and for Apple devices on the App Store. The app is free.

How to get consumption data to your smartphone:

1. Download VertoMobile from your app store.
2. Log into the app using the PIN code shown on the household display. You can find the code under Settings in the Additional Information view of the household display.
3. Once you have configured the number of residents in the household and the water price data on VertoMobile, you will see your consumption also in euros.

The water price data is available from your rental housing company, or the board or building manager of your housing company.



NOTE! If your mobile device changes, water consumption data will be available on the new device from the moment you log in to VertoMobile.

Settings 2: Language option

Select the desired language with the button.

Confirm the selection by pressing the > button.

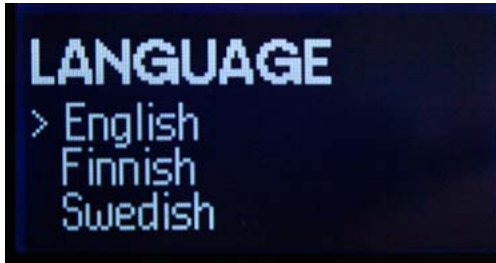

Messages to the end user:

Notification messages can be sent to the residents.
The messages are displayed for five seconds after switch-on,
until the sender deletes the message.

JOIN HUNDREDS OF THOUSANDS OF SATISFIED CUSTOMERS.



Finland's leading water consumption data expert

Contact us – we'll be happy to tell you more!
tel. +358 10 734 0700 • verto@verto.fi • verto.fi



VertoNordic Oy

Hopunkatu 11 • 38200 Sastamala, Finland
tel. +358 10 734 0700 • verto@verto.fi • verto.fi



Great Place to Work®
-certified